

**WILLIAMS TOWNSHIP ZONING OFFICE**

WILLIAMS TWSP. MUNICIPAL BLDG

655 CIDER PRESS ROAD

EASTON, PA. 18042

PHONE 610-258-0522 FAX 610-258-6080

**Application for Drive way, Right-of-Way Occupancy/Road Opening Permit**

Amended November 15, 2012 – Ordinance # 2012-06

- 1) Permit #:
- 2) Owner of Structure, Address and Phone #:
- 3) Contractor's name, Address and Phone #:
- 4) Tax Map ID # & Address where work being done:
- 5) Check all that apply:
  - Driveway:
  - Right-of Way Occupancy:
  - Street Opening Permit:
  - Road Closing Required (Attach detour plan)
- 6) Description of Work (Attach sketch plan or drawing):
  - Quantity of Pavement to be replaced:
  - Length and width of road cut:
  - A \$ 250.00 escrow fee for old and \$ 500.00 for new construction will be held.**
  - Anticipated start date and duration of work:
- 7) **Permittee subject to Ordinance No. 2012-06, Schedule "A" Insurance, Fee, Escrow and deposit requirements and Schedule "B" "Minimum Use Driveway Construction Standards".** Permittee responsible for contacting "PA One-Call System". Performance of regulated activities within the Township right-of-way without a permit is illegal. Violators shall be subject to a fine.
- 8) All work to be done in accordance and subject to Title 67 PACode, Chapter 203 (Work Zone Traffic Control).
- 9) Permit expires one (1) year after authorization date.
- 10) **I/We agree to protect, defend, indemnify and save harmless the Township, Officers or Agents thereof, from all claims, suits, actions and proceedings of**

**every nature and description whatsoever which may be brought against the Township Officers or Agents thereof, for or on account of any injuries or damages to persons and/or public or private property, due to any materials or applications and in the work or by or on account of improper materials of workmanship, or for on account of any accident or any other act, negligence or omissions of said applicant or his agents, servants or employees and the Township shall not, in any way, be liable therefore.**

11) Driveway sight distance measurements?

Signed and Dated for Owner or Contractor:

Emergency contact person during off-business hours:

---

TOWNSHIP USE ONLY

Right-of-Way Occupancy Fee:	\$ 50.00
Road Opening Fee:	\$ 100.00
Detour Plan Fee:	\$ 50.00
Minimum Driveway:	\$ 50.00
Access Driveway:	\$ 75.00
Inspection/Review Escrow:	\$ 250.00 – existing; \$500.00– New
Security Deposit:	
Fee/Deposit received by and Date:	
Permit Authorized by and Date:	
Insurance Certificate received YES or NO	

# DRIVEWAY SIGHT DISTANCE MEASUREMENTS

(FOR LOCAL ROADS, USE PENNDOT PUB 70)

APPLICANT \_\_\_\_\_ APPLICATION NO. \_\_\_\_\_

S.R. \_\_\_\_\_ SEG. \_\_\_\_\_ OFFSET \_\_\_\_\_ LEGAL SPEED LIMIT \_\_\_\_\_

MEASURED BY \_\_\_\_\_ DATE \_\_\_\_\_

FOR DEPARTMENT USE ONLY: Safe-Running Speed \_\_\_\_\_ 85th Percentile Speed \_\_\_\_\_

## A

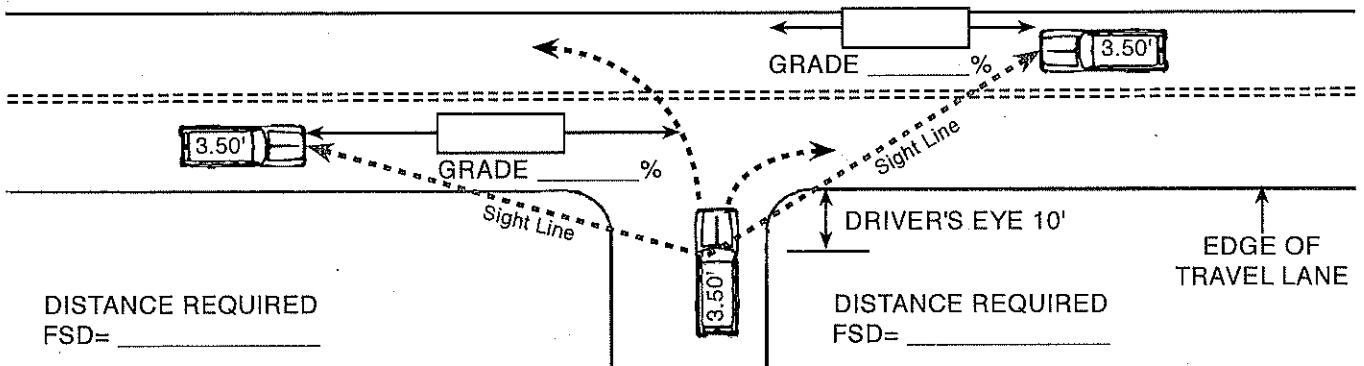

THE MAXIMUM LENGTH OF ROADWAY ALONG WHICH A DRIVER AT A DRIVEWAY LOCATION CAN CONTINUOUSLY SEE ANOTHER VEHICLE APPROACHING ON THE ROADWAY.

## B

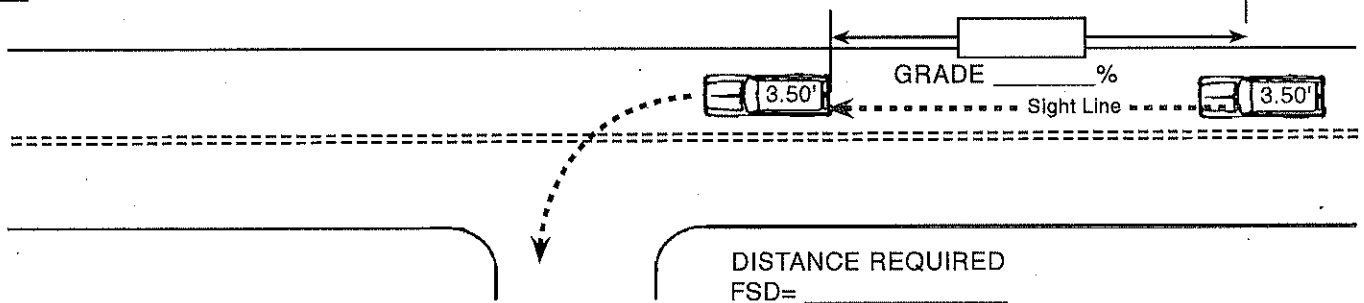

THE MAXIMUM LENGTH OF ROADWAY ALONG WHICH A DRIVER ON THE ROADWAY CAN CONTINUOUSLY SEE THE REAR OF A VEHICLE WHICH IS LOCATED IN THE DRIVER'S TRAVEL LANE AND WHICH IS POSITIONED TO MAKE A LEFT TURN INTO A DRIVEWAY.

## C

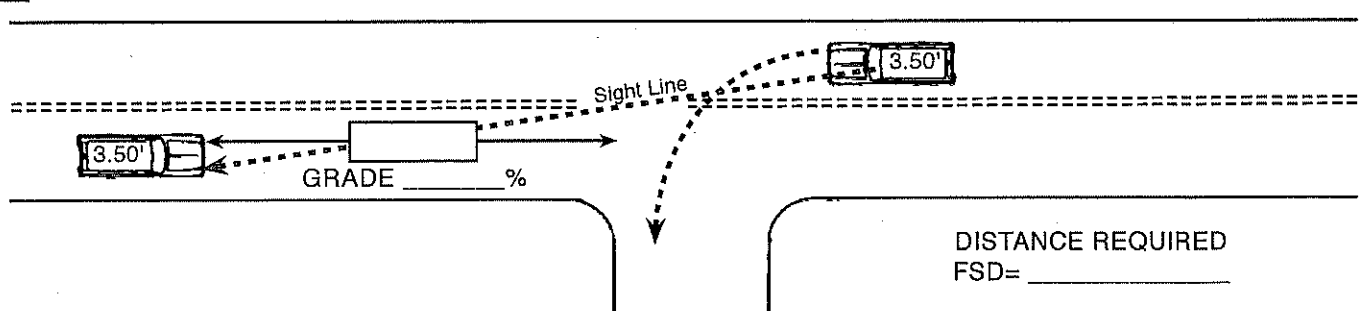

THE MAXIMUM LENGTH OF ROADWAY ALONG WHICH A DRIVER OF A VEHICLE INTENDING TO MAKE A LEFT TURN INTO A DRIVEWAY CAN CONTINUOUSLY SEE A VEHICLE APPROACHING FROM THE OPPOSITE DIRECTION.

## FORMULA SIGHT DISTANCE TABLE

Speed (V) (Miles Per Hour)	Average Grade (G) (Percent)										
	<b>Use plus grades when approaching vehicle is travelling upgrade.</b>										
	0.0	+1.0	+2.0	+3.0	+4.0	+5.0	+6.0	+7.0	+8.0	+9.0	+10.0
25	147	145	144	143	142	140	139	138	137	136	135
30	196	194	191	189	187	185	183	182	180	178	177
35	249	245	242	239	236	233	231	228	226	224	221
40	314	309	304	299	295	291	287	284	280	277	274
45	383	376	370	364	358	353	348	343	339	334	330
50	462	453	444	436	429	422	415	409	403	397	392
55	538	527	517	508	499	490	482	475	468	461	454
	<b>Use negative grades when approaching vehicle is travelling downgrade.</b>										
	0.0	-1.0	-2.0	-3.0	-4.0	-5.0	-6.0	-7.0	-8.0	-9.0	-10.0
25	147	148	150	151	153	155	157	159	161	164	166
30	196	199	201	204	207	210	214	217	221	226	230
35	249	252	256	260	265	269	275	280	286	292	299
40	314	319	325	331	338	345	352	360	369	379	389
45	383	390	398	406	415	425	435	447	459	472	487
50	462	471	481	492	504	517	531	546	563	581	600
55	538	550	562	576	590	606	622	641	661	682	706

**SCHEDULE "A"**  
**INSTRUCTIONS FOR APPLICATION FOR DRIVEWAYS RIGHT-OF-WAY  
OCCUPANCY/  
ROAD OPENING PERMIT**

1. The purpose of this permit program is to regulate the placement of certain structures within Township road rights-of-way and activities conducted within the right-of-way.
2. A Right-of-Way Occupancy Permit is required for installing new structures above or below ground within the road right-of-way such as, but not limited to, driveways, utility poles, guy wires, guide rails, gas, electric, sewer, water, telephone, cable TV, storm and culvert swales, and any other conduit or cable installations including their associated appurtenances. The installation of mailboxes are not regulated by this Ordinance.
3. A Road Opening Permit is required for any activity in the right-of-way that obstructs the travelways or the right-of-way drainage. Activities requiring a permit include, but are not limited to, scheduled repair, modifications, or removal of aboveground or underground utilities or structures, conduit or cable, or associated appurtenances and surface drainways within the right-of-way. Any activities that require the obstruction of the travelway or drainageway require a permit. Cutting of trees and vegetation, coating/repair of private driveways, and emergency repairs of utility service within the limits of right-of-way are not regulated by this Ordinance.
4. A Right-of-Way Occupancy Permit for a driveway must be obtained prior to the issuance of a Building Permit. A Building Occupancy Permit will not be issued until the requirements of the Right-of-Way Occupancy Permit are met.
5. For proposed minimum use driveways, a sketch shall be attached to the application for Right-of-Way Occupancy Permit. All other applications for Right-of-Way Occupancy or Road Opening Permits shall be accompanied by a scaled drawing locating and describing the occupancy and proposed construction in relation to the Township road right-of-way line. Easement descriptions are required for private utility placements.
6. Temporary road closing requests should be accompanied by information as to the duration of the closing and timing, as well as, a Route and Signing Plan (MUTCD-2009, PennDOT Publications 203-Work Zone Traffic Control, Pub 213-Work Zone Traffic Control Guidelines and Pub 23 4-Flagging Handbook) subject to approval by the Township. Proper notification of emergency services, the Township Supervisors, and others identified by the review of this application will be the responsibility of the permittee.
7. During construction, a tire-cleaning mat must be installed at the driveway entrance in accordance with the Northampton County Conservation District Soil and Erosion Control Standards. No other entrance/exit to the property may be utilized.

8. The applicant shall make provisions to maintain uninterrupted parallel drainage along an existing roadway at the location of the proposed driveway, or with any modification to an existing driveway. To ensure compliance, a pre-construction meeting with the Township's Public Works Director or his designee is required.
9. Insurance requirements, escrows, and required security deposits shall be in accordance with the Schedule "B" adopted by the Board of Supervisors for this Ordinance.
10. The Fees, Engineering Review Escrow, and Security Deposit will be collected at the time the application is submitted to the Township. The Security Deposit will be per Schedule "B". The Township shall issue a permit within fifteen (15) days of submission unless the application and supporting documentation is incomplete. Seventy-five (75%) percent of the Deposit will be refunded when the work is accepted by the Township as evidenced with a final inspection by the Public Works Director or his designee. The refund will be no later than thirty (30) days upon notification that the work is completed. The remaining twenty-five (25%) percent of the deposit will be refunded one (1) year after the initial refund is made provided the condition of the pavement remains satisfactory. If unsatisfactory restoration is made or the permittee is not able to satisfy the Township or is unresponsive, action will be taken by the Township in accordance with the Ordinance.
11. All restoration work must be executed in accordance with this Ordinance or the approved plans for a subdivision/land development.
12. An initial minimum Engineering Review Escrow (per Schedule "B") shall be posted by the applicant, if it is determined that review and/or inspection by the Township will be required. Additional deposits may be required depending on the complexity of the project.
13. For a road opening permit involving an access drive, local road or private road, safe sight distances shall meet the minimum requirements set forth by the Township's zoning ordinance. Required sight distances will be checked by the Public Works Director or his designee and shall be found in compliance before the access drive, local road or private road is opened.

SCHEDULE "B"

INSURANCE, ESCROW, AND DEPOSIT REQUIREMENTS  
DRIVEWAYS RIGHT-OF-WAY OCCUPANCY/STREET OPENING PERMIT  
APPLICATIONS

1. The following application fees shall apply:

Minimum Use Driveway	\$50.00
Access Drive	\$75.00
Right of Way Occupancy	\$50.00
Street Opening (Utility)	\$100.00

2. The following Engineering Review Escrow requirements apply:

If a review by the Township Engineer or inspection of the work is deemed to be necessary by the Township, the fees for such work will be charged against a review and inspection escrow account in accordance with the Township's Schedule of Rates for Professional Engineering Services. If an escrow deposit is required, a minimum of \$250.00 for old construction and \$500.00 for new construction, shall be provided by the applicant to offset anticipated review or inspection fees. Unused escrow balance will be refunded to the applicant following satisfactory completion of the work.

3. Computation of security deposit:

The amount of security to be deposited for street opening applications shall be based on the area of pavement that will be required for restoration of the roadway surface. The deposit amount shall be \$25.00 per square yard times the quantity of roadway pavement anticipated for replacement. The minimum deposit shall be \$250.00.

Inspection by the Township or its authorized agent shall occur upon notice by the permittee that the work has been satisfactorily completed. If inspection indicates that the work is acceptable, the security deposit will be released in accordance with the provisions of the ordinance.

4. Contractors shall provide evidence of general liability coverage in an amount not less than \$1,000,000.00.
5. If the proposed occupancy or street opening is covered by an Improvements Agreement through the Subdivision and Land Development approval process, the escrow and security deposit are waived.

## SCHEDULE "C"

### MINIMUM USE DRIVEWAY DESIGN & CONSTRUCTION STANDARDS

- A. The initial twenty (20') feet from the edge of cartway shall not exceed:  
6% for local and collector streets  
4% for arterial streets
- The overall maximum slope shall not exceed 15%.
- B. The minimum driveway width for minimum use driveways is ten (10') feet. The driveway is to intersect the existing roadway at ninety degrees ( $90^{\circ} \pm 25^{\circ}$ ) and have a minimum five (5') foot return radius on each side where curbing is not provided. All other access way width shall be pursuant to the Township SALDO or PennDOT Chapter 441, Access to and Occupancy of Highways By Driveways and Local Roads.
- C. The minimum use driveway shall be paved for the initial twenty (20') feet. The applicant/owner shall maintain the initial twenty (20') feet in a paved condition. If this requirement cannot be accomplished at the issuance of a Certificate of Use and Occupancy a \$1,000.00 escrow shall be collected to ensure this has been accomplished. If not accomplished within one (1) year from issuance of Certificate of Use and Occupancy, Williams Township can use this escrow to pave the initial (20) feet of driveway. Unused escrow balance will be refunded to the applicant following satisfactory completion of the work. The pavement shall consist of a minimum of three (3") inches of 2A crushed aggregate and one and one-half (1 ½") inch of superpave wearing course.
- D. A "C"-Swale/Gutter cross section shall be provided across the proposed paved driveway where said driveway intersects non-curbed roads. The cross section geometry shall be maintained so as to allow for unimpeded stormwater flow.
- E. If the applicant/owner requests a culvert installation, appropriate sketches and calculations shall be submitted to the Township for review and approval a minimum of fifteen (15) days prior to planned construction. Pipe material is to be RCP or HDPE, with flared end sections and a minimum fifteen (15") inch diameter. The crown of the pipe is to be set 12" below the finished paved driveway over the pipe as located at the centerline of driveway.
- F. All disturbed areas within the Township right-of-way, but not including the paved driveway, shall be graded and stabilized according to approved Subdivision/Land Development Plans if applicable, or otherwise returned to preexisting conditions.
- G. The applicant/owners shall be responsible for incorporating standard erosion and sedimentation control practices during the driveway construction. Cleanup of offsite sediment or repair of offsite erosion will be at the applicant's/owner's responsibility.



- H. The owner/applicant shall provide temporary traffic control devices and procedures in accordance with MUTCD and PennDOT Publications 203, 213 and 234.
- I. Where the combination of a proposed driveway (including non-paved portions) or any other impervious surface exceeds 10,000 square feet, a Stormwater Management Plan must be submitted to the Lehigh Valley Planning commission. The plan must be consistent with the Frys Run Act 167 Stormwater Management Plan.
- J. The maximum number of minimum use driveways allowed per lot shall be two, with a minimum spacing between driveways of 50 feet.
- K. Contact the Pennsylvania One Call System three business days before digging, call 811 or 1-800-242-1776.
- L. All driveways shall provide, wherever possible, appropriate accessibility based on the American with Disabilities Act (ADA) across all driveways/curb cuts. Reference should be made to the ADA Accessible Rights-of-Way manual.
- M. Safe driveway sight distance shall be indicated on the sketch as obtained from actual field measurement. Measurement of sight distance shall be measured in accordance with the requirements of PennDOT and attested by the owner's signature on the application. Information shall include the posted speed limit and the grade of the intersected road. A field stake/lathe shall be placed 10' back from the edge of the cartway pavement at the centerline of the proposed minimum use driveways, (15' back for other driveways, access drives and intersections). The minimum sight distances for minimum use driveways shall conform to PennDOT Form M-950S, as amended. For all other driveways, access drive and intersections sight distance shall be in accordance with the Township's zoning ordinance.
- N. A minimum use driveway shall be located a minimum 3 feet from a side or rear lot line adjacent to a residential use or residential zoned property.
- O. Driveways shall intersect roads at ninety ( $90^{\circ}$ )  $\pm$  25 $^{\circ}$ , as approved by the Township.

**SCHEDULE "D"**  
**EXCAVATION/BACKFILL/PAVEMENT RESTORATION STANDARDS**

1. All street excavation and roadway restoration shall be in accordance with the following minimum standards (see also Trench and Restoration Details):

- A. Trench Backfill

Cut trench and excavate  
Install granular bedding and initial backfill, as required by utility  
2A crushed stone backfill; 8" lifts, tamped to surface

- B. Temporary Roadway Replacement (required for 30-60 days)

2A crushed stone, tamped  
2" approved cold patch, compacted  
Maintenance for 30 to 60 days

- C. Permanent Hard Surfaced Roadway Replacement within 60 days

Saw cut trench to cut back of 12 inches  
Excavate to minimum depth required for placement of full Section or as directed  
4" 2A crushed stone  
4 ½" base course Pg. 64-22, 25 mm. superpave asphalt  
1 ½" wearing course Pg. 64-22, 9.5 mm. mixture, SRL-H  
Joint or edge sealing

- D. Permanent Gravel Surfaced or Unsurfaced Roadway/Shoulder Replacement

Replace existing surface material in kind and compact

2. Minimum use driveway construction shall be in accordance with Minimum Use Driveway Construction Standards (Schedule "C") and the Minimum Use Driveway Details

Areas outside the roadway shall be properly restored, graded, topsoiled, seeded and mulched, industrial driveway restoration included. Roadside swales and ditches and drainage facilities shall be restored to original design grades. All disturbed areas shall be stabilized in accordance with acceptable practices for soil erosion and sedimentation control. NOTE: Disturbed areas exceeding one acre require County Conservation District review. Pavement construction and restoration work shall be in accordance with the latest edition of the Department of Transportation's Form 408, except as specified by Township Ordinance.

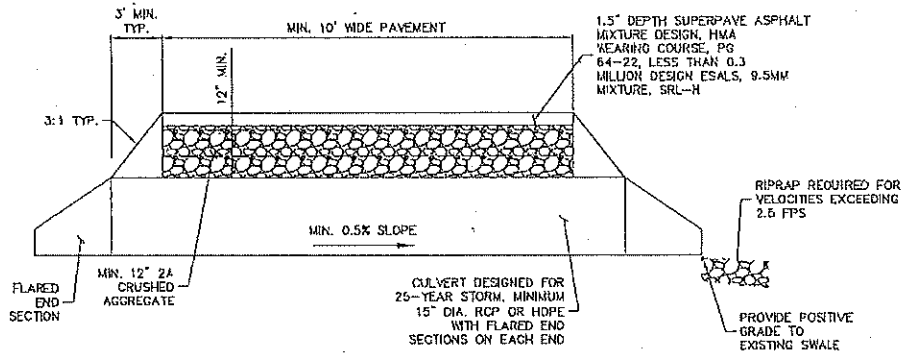

**DRIVEWAY CROSS-SECTION DETAIL**  
NOT TO SCALE

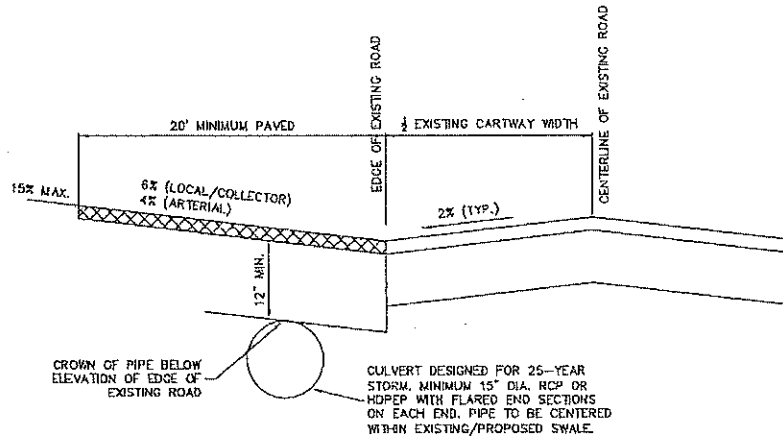

**NOTES:**

1. INITIAL 20 FEET OF DRIVEWAY MUST BE PAVED.
2. INITIAL 20 FEET - 4% MAXIMUM SLOPE FOR DRIVEWAYS ACCESSING ARTERIAL ROADS, 6% MAXIMUM SLOPE FOR DRIVEWAYS ACCESSING LOCAL AND COLLECTOR ROADS.
3. BEYOND INITIAL 20 FEET, MAXIMUM DRIVEWAY SLOPE SHALL NOT EXCEED 15%.

**DRIVEWAY WITH CULVERT DETAIL**  
NOT TO SCALE



74 WEST BROAD STREET, SUITE 240  
BETHLEHEM, PA. 18018  
TEL: 610-625-2899  
FAX: 610-625-2969

**MINIMUM USE DRIVEWAY DETAILS**

WILLIAMS TOWNSHIP  
NORTHAMPTON COUNTY  
PENNSYLVANIA

SCALE: N.T.S.

DATE: 1/19/12

SHEET 1 OF 7

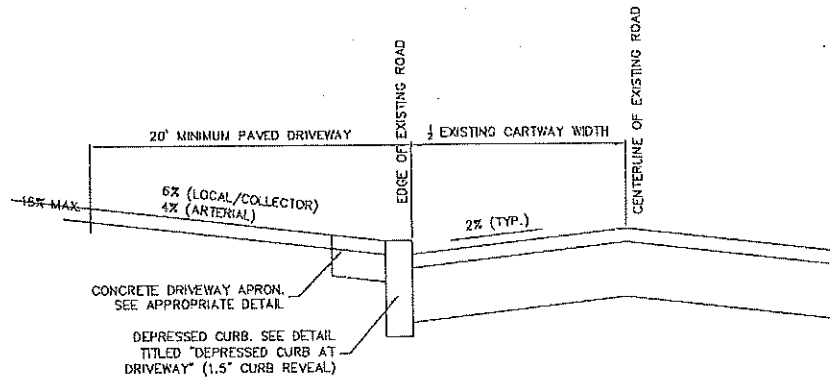

**NOTES:**

1. INITIAL 20 FEET OF DRIVEWAY MUST BE PAVED.
2. INITIAL 20 FEET - 4% MAXIMUM SLOPE FOR DRIVEWAYS ACCESSING ARTERIAL ROADS, 6% MAXIMUM SLOPE FOR DRIVEWAYS ACCESSING LOCAL AND COLLECTOR ROADS.
3. BEYOND INITIAL 20 FEET, MAXIMUM DRIVEWAY SLOPE SHALL NOT EXCEED 15%.

**DRIVEWAY WITH APRON DETAIL**

NOT TO SCALE

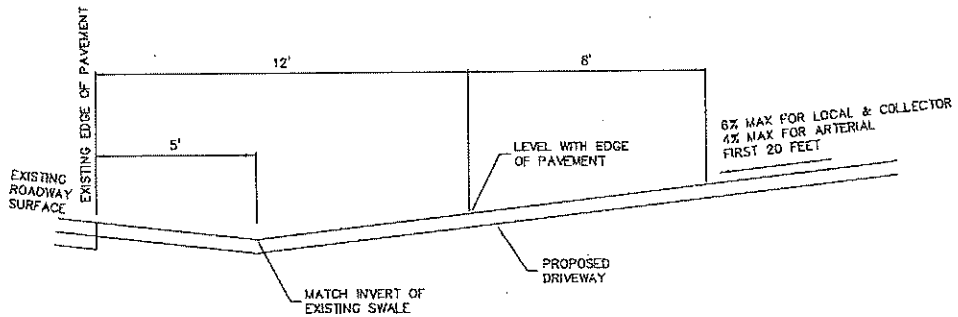

**DRIVEWAY SWALE DETAIL**

NOT TO SCALE



74 WEST BROAD STREET, SUITE 240  
 BETHLEHEM, PA. 18018  
 TEL: 610-625-2999  
 FAX: 610-625-2969

**MINIMUM USE DRIVEWAY DETAILS**

WILLIAMS TOWNSHIP  
 NORTHAMPTON COUNTY  
 PENNSYLVANIA

SCALE: N.T.S.

DATE: 1/19/12

SHEET 2 OF 7

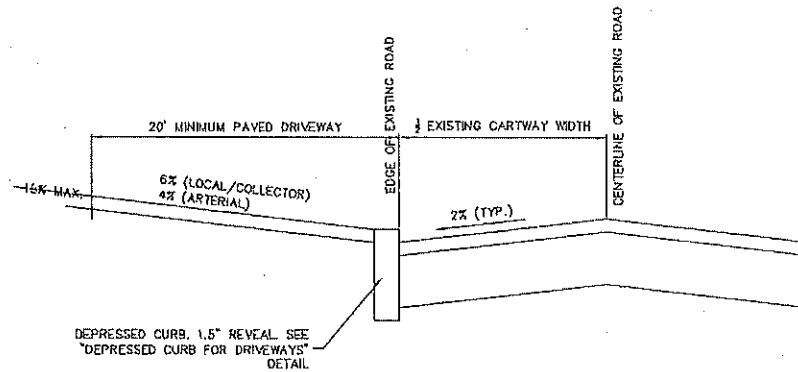

**NOTES:**

1. INITIAL 20 FEET OF DRIVEWAY MUST BE PAVED.
2. INITIAL 20 FEET -- 4% MAXIMUM SLOPE FOR DRIVEWAYS ACCESSING ARTERIAL ROADS, 6% MAXIMUM SLOPE FOR DRIVEWAYS ACCESSING LOCAL AND COLLECTOR ROADS.
3. BEYOND INITIAL 20 FEET, MAXIMUM DRIVEWAY SLOPE SHALL NOT EXCEED 15%.

DRIVEWAY WITH DEPRESSED CURB  
AND NO SIDEWALK  
NOT TO SCALE

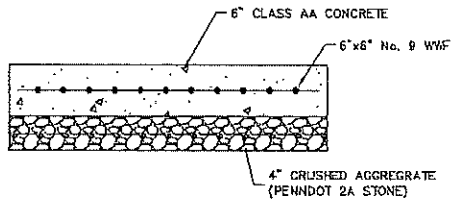

**NOTES:**

1. ALL JOINTS TO BE FILLED WITH 1/2" PREMOULDED EXPANSION JOINT MATERIAL.
2. 4" CRUSHED AGGREGATE PENNDOT 2A STONE BASE TO BE MECHANICALLY TAMPED.
3. 6"x6" No. 9 WWF TO BE INSTALLED IN CONCRETE WITH MINIMUM SPACING = 3" AND MINIMUM CLEARANCE = 0.5"

DRIVEWAY APRON CROSS-SECTION  
NOT TO SCALE



74 WEST BROAD STREET, SUITE 240  
BETHLEHEM, PA. 18016  
TEL: 610-525-2999  
FAX: 610-525-2999

**MINIMUM USE DRIVEWAY DETAILS**

WILLIAMS TOWNSHIP  
NORTHAMPTON COUNTY  
PENNSYLVANIA

SCALE: N.T.S.

DATE: 1/19/12

SHEET 3 OF 7

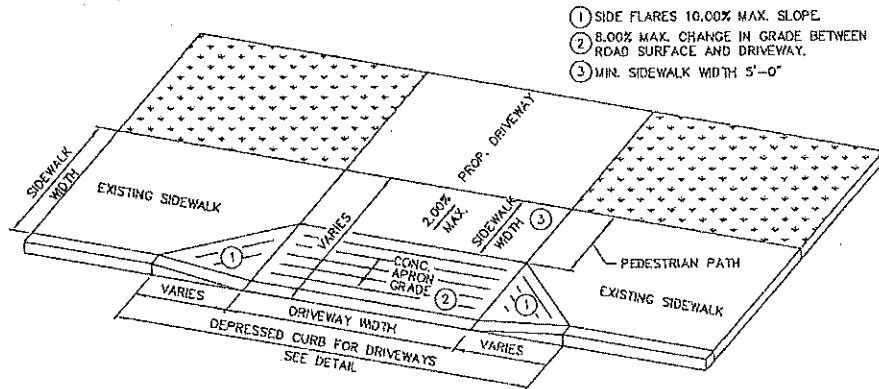

**NOTES:**

1. SEE 'DRIVEWAY APRON CROSS-SECTION' DETAIL FOR CONCRETE THICKNESS, STONE BASE THICKNESS AND WWF INFORMATION.
2. PROVIDE MATERIALS AND CONSTRUCTION MEETING THE REQUIREMENTS OF PENNDOT PUBLICATION 408
3. CONCRETE SHALL BE CLASS AA WITH A 28-DAY STRUCTURAL DESIGN COMPRESSIVE STRENGTH OF 3,500 PSI.
4. SPACE CONTRACTION JOINTS IN UNIFORM LENGTHS OR SECTIONS.
5. PLACE 1/4" THICK PREMOULDED EXPANSION JOINT FILLER MATERIAL AT STRUCTURES AND AT THE END OF THE WORK DAY. CUT MATERIAL TO CONFORM TO AREA ADJACENT TO APRON OR TO CONFORM TO CROSS SECTIONAL AREA OF APRON.

**DRIVEWAY APRON - TYPE 1A**

NOT TO SCALE

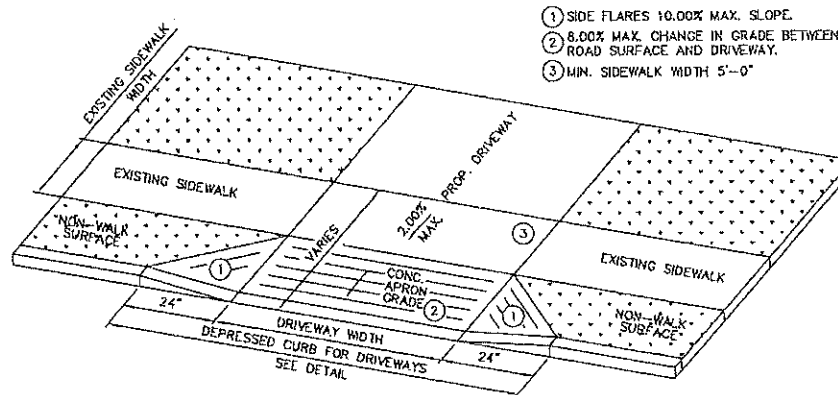

**NOTES:**

1. SEE 'DRIVEWAY APRON CROSS-SECTION' DETAIL FOR CONCRETE THICKNESS, STONE BASE THICKNESS AND WWF INFORMATION.
2. PROVIDE MATERIALS AND CONSTRUCTION MEETING THE REQUIREMENTS OF PENNDOT PUBLICATION 408
3. CONCRETE SHALL BE CLASS AA WITH A 28-DAY STRUCTURAL DESIGN COMPRESSIVE STRENGTH OF 3,500 PSI.
4. SPACE CONTRACTION JOINTS IN UNIFORM LENGTHS OR SECTIONS.
5. PLACE 1/4" THICK PREMOULDED EXPANSION JOINT FILLER MATERIAL AT STRUCTURES AND AT THE END OF THE WORK DAY. CUT MATERIAL TO CONFORM TO AREA ADJACENT TO APRON OR TO CONFORM TO CROSS SECTIONAL AREA OF APRON.

**CONCRETE DRIVEWAY APRON - TYPE 1**

NOT TO SCALE



74 WEST BROAD STREET, SUITE 240  
 BETHLEHEM, PA. 18018  
 TEL: 610-625-2999  
 FAX: 610-625-2999

**MINIMUM USE DRIVEWAY DETAILS**

WILLIAMS TOWNSHIP  
 NORTHAMPTON COUNTY  
 PENNSYLVANIA

SCALE: N.T.S.

DATE: 1/19/12

SHEET 4 OF 7

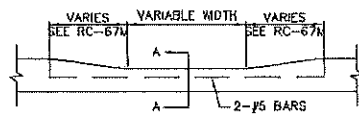

ELEVATION

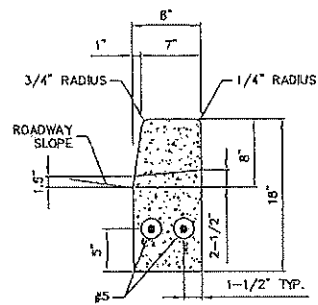

SECTION A-A

NOTES:

1. PROVIDE MATERIALS AND CONSTRUCTION MEETING THE REQUIREMENTS OF PENNDOT PUBLICATION 40B, SECTION 630 FOR PLAIN CEMENT CONCRETE CURB AND DEPRESSED CURB
2. CONCRETE SHALL BE CLASS AA WITH A 28-DAY STRUCTURAL DESIGN COMPRESSIVE STRENGTH OF 3,500 PSI.
3. SPACE CONTRACTION JOINTS IN UNIFORM LENGTHS OR SECTIONS.
4. PLACE 3/4" THICK PREMOLED EXPANSION JOINT FILLER MATERIAL AT STRUCTURES AND AT THE END OF THE WORK DAY. CUT MATERIAL TO CONFORM TO AREA ADJACENT TO CURB OR TO CONFORM TO CROSS SECTIONAL AREA OF CURB.
5. FOR USE IN AREAS OTHER THAN PEDESTRIAN CURB RAMPS.

DEPRESSED CURB FOR DRIVEWAYS

NOT TO SCALE



74 WEST BROAD STREET, SUITE 240  
 BETHLEHEM, PA. 18018  
 TEL: 610-625-2999  
 FAX: 610-625-2969

MINIMUM USE DRIVEWAY DETAILS

WILLIAMS TOWNSHIP  
 NORTHAMPTON COUNTY  
 PENNSYLVANIA

SCALE: N.T.S.

DATE: 1/19/12

SHEET 5 OF 7

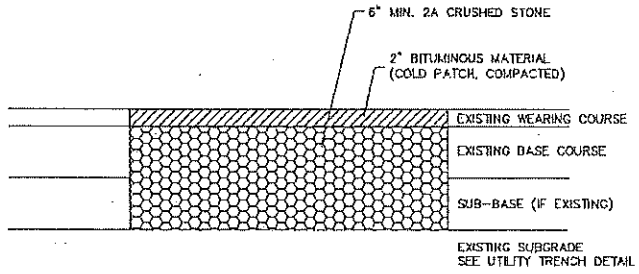

**TEMPORARY RESTORATION**  
NOT TO SCALE

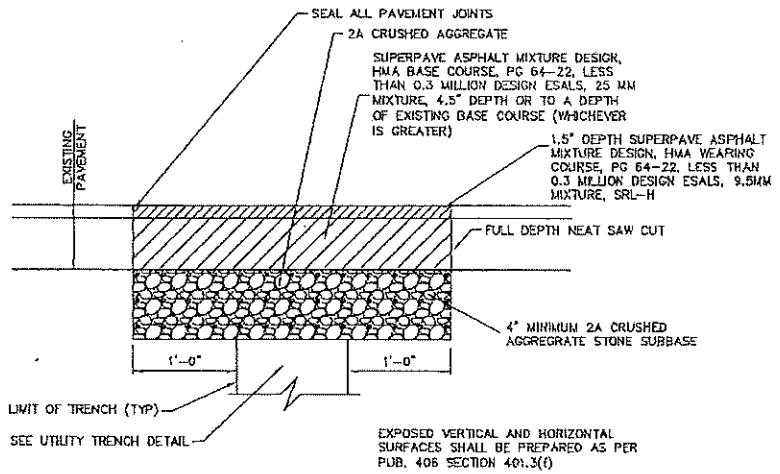

**PERMANENT PAVEMENT RESTORATION**  
NOT TO SCALE



74 WEST BROAD STREET, SUITE 240  
BETHLEHEM, PA. 18018  
TEL: 610-625-2989  
FAX: 610-625-2969

**BACKFILL & RESTORATION DETAILS**

WILLIAMS TOWNSHIP  
NORTHAMPTON COUNTY  
PENNSYLVANIA

SCALE: N.T.S.

DATE: 1/19/12

SHEET 6 OF 7



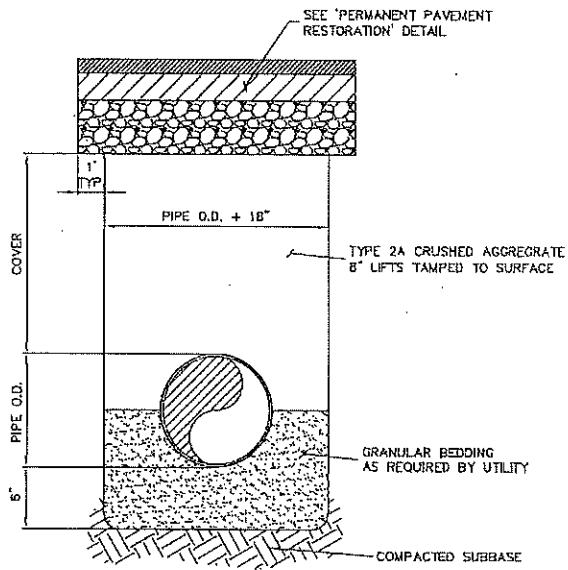

TRENCH IN PAVED ROADWAYS

NOTES

1. PLACE AND COMPACT ALL TRENCH MATERIAL (INCLUDING SUB-BASE) IN 8 INCH LIFTS, TO A MINIMUM OF 90% DRY WEIGHT DENSITY.

TYPICAL TRENCH DETAILS

NOT TO SCALE



74 WEST BROAD STREET, SUITE 240  
 BETHLEHEM, PA. 18018  
 TEL: 610-625-2999  
 FAX: 610-625-2959

**BACKFILL & RESTORATION DETAILS**

WILLIAMS TOWNSHIP  
 NORTHAMPTON COUNTY  
 PENNSYLVANIA

SCALE: N.T.S.

DATE: 1/19/12

SHEET 7 OF 7

